

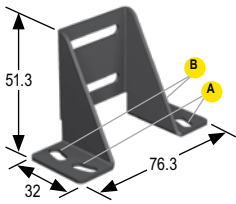

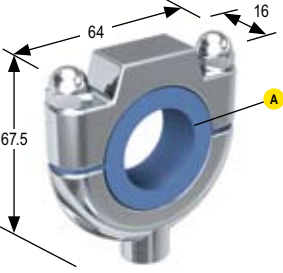
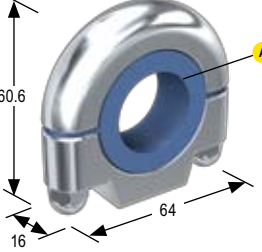
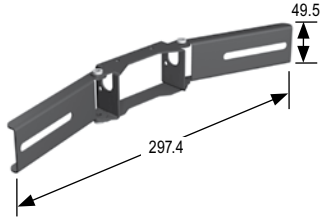
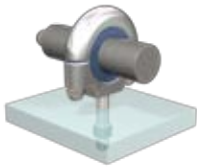

| SMBLXR | SMBM25A | SMBM25B | SMBP42ASM |
|---|---|--|--|
|  <p>All measurements in mm</p> |  <p>All measurements in mm</p> |  <p>All measurements in mm</p> |  <p>All measurements in mm</p> |
| <p>Hole center spacing: A, B = 63.5, A to B = 10.2 Hole size: A, B = 5.2 x 11.6</p> | <p>Hole size: A = \varnothing 25.4</p> | <p>Hole size: A = \varnothing 25.4</p> | <p>N/A</p> |
| <ul style="list-style-type: none"> • Back-mount bracket for secure one-end mounting • Zinc-plated cold-rolled steel | <ul style="list-style-type: none"> • Top mount swivel bracket • Stainless steel with rounded edges for cleanliness in demanding environments • Non-metallic FDA compliant bushing for acoustically isolating M25U sensors • M10 x 1.5 mount on opposite side of clamping nuts | <ul style="list-style-type: none"> • Bottom mount swivel bracket • Stainless steel with rounded edges for cleanliness in demanding environments • Non-metallic FDA compliant bushing for acoustically isolating M25U sensors • M10 x 1.5 mount on same side as clamping nuts | <ul style="list-style-type: none"> • For mounting two lights to P4 sensor housing • Black corrosion-resistant zinc finish • Hardware included |
| <p>Back Mount</p> | <p>Barrel Mount</p> | <p>Barrel Mount</p> | <p>Light-to-Sensor</p> |
|  <p>Used with</p> |  <p>Used with</p> |  <p>Used with</p> |  <p>Used with</p> |
| <p>LX</p> | <p>M25U</p> | <p>M25U</p> | <p>Area Light (80 x 80 mm)* Area Light (62 x 62 mm) Spot Light</p> |
| | | | <p>* Requires one SMBACM bracket with each light (see page 646)</p> |

- Accessories
- Brackets
- Cordsets
- Retroreflectors
- Miscellaneous
- Reference

More on next page